

MULTIRAY SERIES

MEDIUM PRESSURE UV AGAINST COMBINED CHLORINE, CRYPTO AND GIARDIA



ULTRAQUA
UV DISINFECTION SYSTEMS

WE PROTECT YOUR MOST VALUABLE RESOURCE

MULTIRAY SERIES

THE MULTIRAY SERIES IS DEVELOPED FOR EXCELLENT DISINFECTION AND CHLORAMINE REDUCTION IN SWIMMING POOLS, BEING OPTIMIZED FOR THE LOWEST POSSIBLE OPERATING COSTS.

KEY HIGHLIGHTS

- High-grade electropolished stainless steel 316L material providing excellent resistance against Cryptosporidium & Giardia
- Low headloss design, minimizing the need for additional pumping
- Tool free lamp service
- Medium-pressure ULTRATHERM 9.000-hour lamp lifetime
- Robust automatic wiper system, reducing the downtime and keeping the UV running optimally
- Easy maintenance and installation
- Sensor removeable during operation for service
- PLC-based controller for easy integration

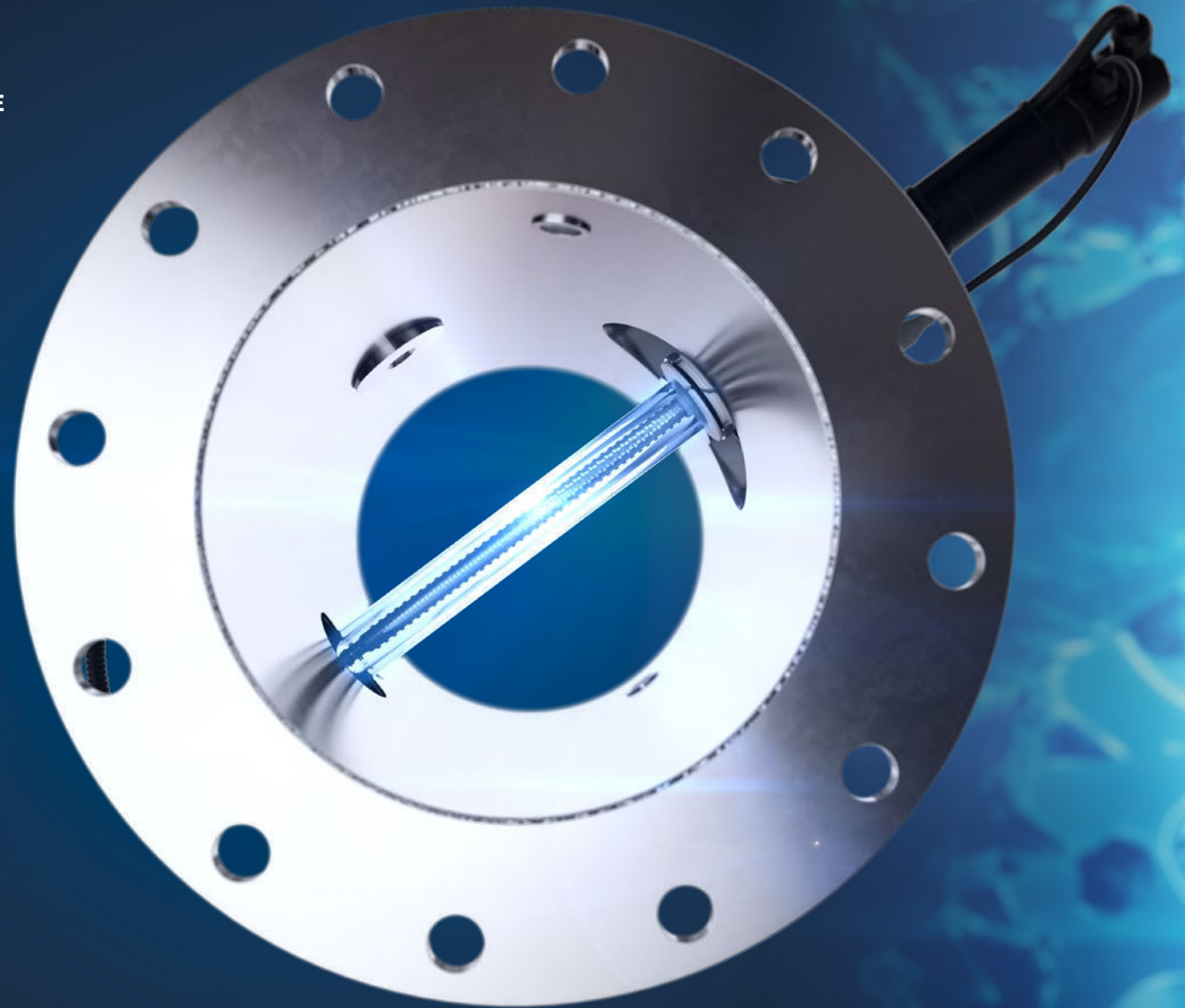

MARKET LEADING ENERGY EFFICIENCY

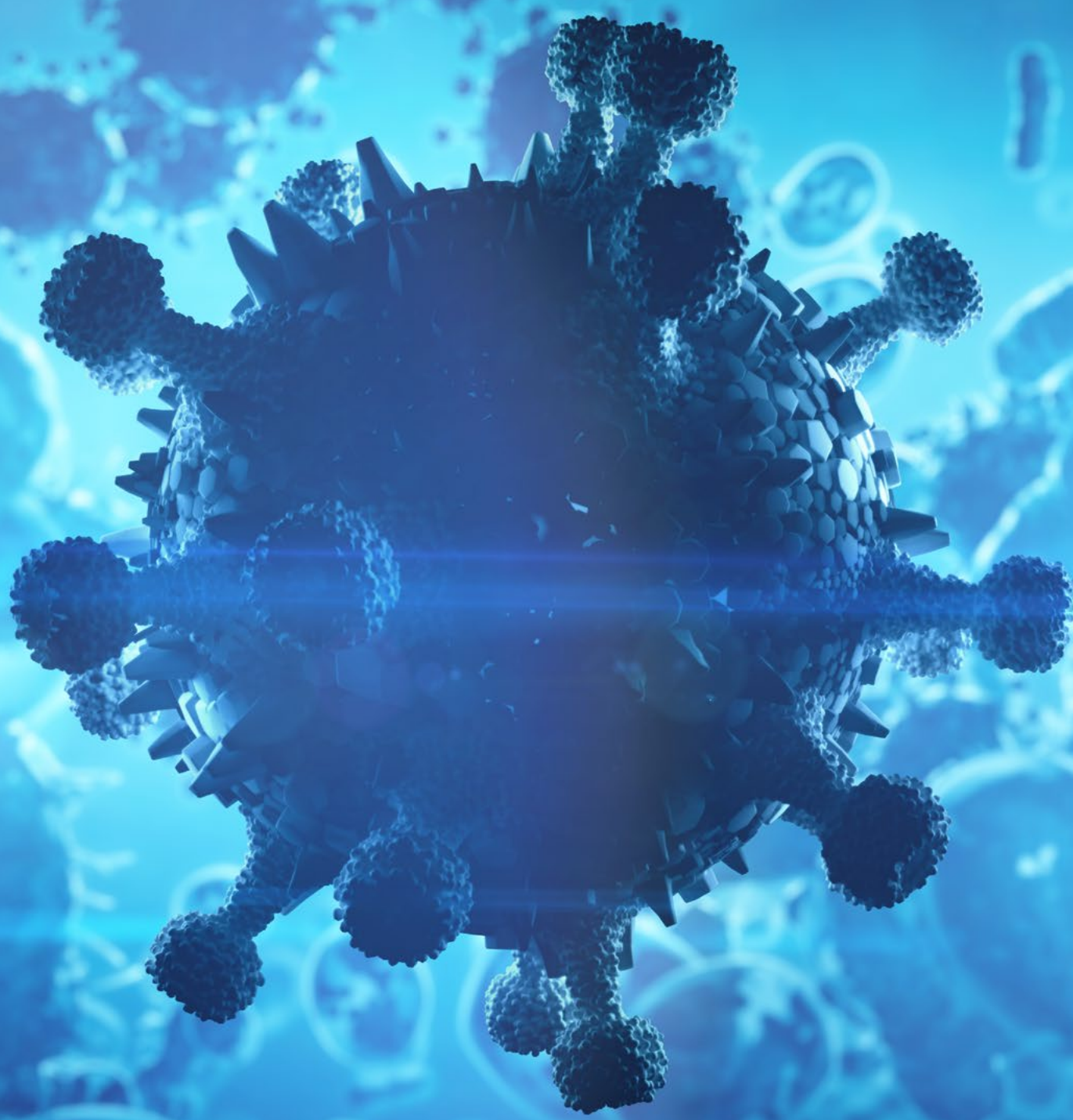

CORE BENEFITS OF UV

UV TECHNOLOGY IS A GLOBALLY ACCEPTED SOLUTION FOR WATER DISINFECTION AND COMBINED CHLORINE REMOVAL.

The demand for cost-efficient solutions to provide high quality disinfected swimming pool water are at an all-time high and will only increase in the future. UV disinfection solves this complex challenge, being able to meet the strictest requirements regarding disinfection and combined chlorine removal.

Improved technological and design configurations have made UV a viable OPEX and CAPEX solution for swimming pools of all sizes.

Choosing to include UV as a secondary disinfection method ensures protection against chlorine resistant pathogens such as Cryptosporidium and Giardia.

The scientifically optimized MULTIRAY systems are designed to remove potential health issues associated with combined chlorine, to ensure a better bather experience.

The ULTRAAQUA UV MULTIRAY systems are easy to install, maintain, and thoroughly cost-optimized. The third-party approvals for performance and quality ensure complete peace of mind, employing the best available solution.

ULTRAAQUA
UV DISINFECTION SYSTEMS

COMPLETE CONTROL WITH ULTRATOUCH CONTROL CABINETS

The market-leading ULTRATOUCH PLC is the very latest in Siemens touch-screen HMI technology. Relevant interfaces and connectors are available, also offering remote operation and dimming functionality.

OPTIMIZED FOR REMOVAL OF COMBINED-CHLORINE

The compact reactor with its CFD optimized lamp positioning makes the MULTIRAY able to offer maximum hydraulic efficiency throughout the entire UVT range with minimum head loss, making the system optimized for combined chlorine removal.



DISINFECTION FIREWALL

The MULTIRAY ensures excellent protection against cryptosporidium and giardia while removing combined chlorine.

POOL SENSOR

High-quality precision sensor, designed for pool UV. Close sensor valve to clean under operation.

TEMPERATURE CONTROL

Overheating and melting damage is avoided with a temperature sensor.





HIGH GRADE 316L STAINLESS STEEL

The high-grade stainless steel offers excellent resistance against chlorides.

EASY MAINTENANCE AND INSTALLATION

With a design that allows for easy maintenance, the system is easily installable and can be serviced using no special tools. The sensor is easily cleaned, serviced or replaced under operation due to the integrated valve. Additionally, the unique interlocking electrical and mechanical lamp connectors make servicing of the system safe, quick, and fool proof.

EXCEPTIONAL LAMP LIFETIME

The integrated ULTRATHERM lamps offer the very latest medium pressure high-intensity UV lamp technology, being optimized for energy efficiency and robustness. The substantial 9,000 hours of lamp lifetime offers market-leading lamp efficiency in UV-C output density.

Additionally, the lamps are operated with an electronic ballast optimizing power use and making lamp function alarm possible.

UV SYSTEM	MP1-1000 MULTIRAY	MP1-2000 MULTIRAY	MP1-3500 MULTIRAY	MP2-3500 MULTIRAY	MP3-3500 MULTIRAY	MP4-3500 MULTIRAY
Product ID	24110	24202	24211	24221	24230	24240
Approvals	CE [UL]					
UV LAMPS & MONITORING						
Total Lamps	1	1	1	2	3	4
ULTRATHERM MPHI Lamp	1000 W	2000 W	3500 W	3500 W	3500 W	3500 W
Total Lamp Power	1000 W	2000 W	3500 W	7000 W	10500 W	14000 W
Expected Lamp Lifetime	9000 Hours					
UV Monitoring	UV Intensity Sensor Pool Specialised					
Variable Power	Automatic ULTRADOSE Pacing 50-100%					
UV CHAMBER						
Connection Size	DN150 / D160	DN200 / D200	DN250 / D250	DN300 / D315	DN300 / D315	DN300 / D315
Connection Type	EN-1092 Type 01A PN10					
Design Pressure	10 Bar					
Chamber Material	SS316L/1.4404					
Internal & External Finish	Electropolished Inside/Out					
Quartz Type	High Purity Fused Quartz Transmittance >95%					
ULTRAWIPER System	Manual Wiper [Automatic Mechanical with PTFE/Fibre Rings - Electrical]					
Temperature Probe	Yes					
Vent / Drain Ports / Air Port	Prepared for 1/2" Valve (Not Included)					
Minor Wetted Parts	FDA Approved PTFE, PVDF, VITON					
Reactor Dry Weight	17 kg	23 kg	28 kg	42 kg	44 kg	46 kg
Reactor Volume	10 kg	18 kg	26 kg	58 kg	58 kg	58 kg
CONTROL CABINET						
Cabinet Material	Powder Painted Steel					
Cabinet Sizes (H×W×D) mm (in)	600×600×300 mm	600×600×300 mm	600×600×300 mm	800×800×300 mm	1000×1000×300 mm	1000×1000×300 mm
Cable Length	4 Meters (Max 30 Meters)					
Installation & Ambient	Wall Mount 0-40 °C Non-Condensing					
Ingress Protection	IP54 [IP65]					
Thermal Control	Fan Cooled System					
Control Logic	PLC					
Interface/HMI	STD.: 4" ULTRATOUCH / ADV.: 7" ULTRATOUCH					
SCADA Communication	MODBUS TCP/IP					
Digital/Analogue 4-20mA I/O	ON Signal / Flow Input / UV Dose Output / Alarm Output					
Remote Monitoring	Yes					
Log	Alarm, Event & Data (UV Dose, UV Intensity, Flow & Combined Chlorine)					
Total Power Consumption	1,1 kW	2,2 kW	3,6 kW	7,2 kW	10,7 kW	14,2 kW
Power Supply	3x 400VAC +/- 10% +N+PE 50/60Hz					
Cabinet Weight	42 kg	42 kg	42 kg	62 kg	75 kg	83 kg
SYSTEM						
Capacity Max Flow 3m/sec.	190 m³/h	300 m³/h	480 m³/h	800 m³/h	800 m³/h	800 m³/h
Flow @ 60m/cm² 95% UVT (3log Crypto + Combined Chlorine Breakdown)	63 m³/h	143 m³/h	275 m³/h	650 m³/h	950 m³/h*	1250 m³/h*
Flow @ 60m/cm² 98% UVT (3log Crypto + Combined Chlorine Breakdown)	82 m³/h	200 m³/h	400 m³/h	1000 m³/h*	1450 m³/h*	1900 m³/h*

European standard for pool designs: 60m/cm² - 95% UVT

TECHNOLOGY OVERVIEW & VALIDATIONS

THE UV SYSTEMS OF ULTRAAQUA HAS UNDERGONE EXTENSIVE TESTING AND PASSED THE WORLD'S MOST RIGOROUS TESTS FOR VALIDATION AND APPROVAL BY RECOGNIZED LEADING CERTIFICATE PROVIDERS.

This means that reliable and thoroughly tested solutions are guaranteed.



The **DVGW certification** assures that critical technical requirements are met regarding hygiene, safety, and general functionality. DVGW is an unbiased technical-scientific association based in Germany, specialized in gas and water industries.



The **AMS (Analog Mixed Signal) verification** ensures that the electronic components are compliant with the latest industry-standard, allowing smooth and quick signal transmission among the electrical components used in data tracking and storage.



The **ETV-EU verification** is a third-party validation of new innovative environmental technologies, ensuring product credibility for the buyer.

ULTRAAQUA
UV DISINFECTION SYSTEMS

CUSTOMIZED SOLUTIONS

ULTRAAQUA UTILIZES AN ENTIRE DEPARTMENT OF ENGINEERS SPECIALIZED IN THE DESIGN AND CONSTRUCTION OF UV SYSTEMS.

Numerous years of experience in various applications enable the adjustment of any standard UV system to accommodate specific requirements.

The customization requirements can vary from adjustments such as reactor shape or flange size to various advanced features.

This enables us to ensure on-site validation to various standards, fitting your exact requirements.

For all customizations, the services and solutions include, but are not limited to:

- Integrated CFD Analysis
- Particle tracing modeling analysis
- Determining fluence rate
- Physical testing
- On-site validation testing
- Solutions for advanced applications
- Packaged plant equipment
- Mobile treatment containers
- Skid packages

Additionally, our engineers are able to assist with installation details such as weir design, water level control devices, and many other project-specific matters.

ULTRAAQUA
UV DISINFECTION SYSTEMS

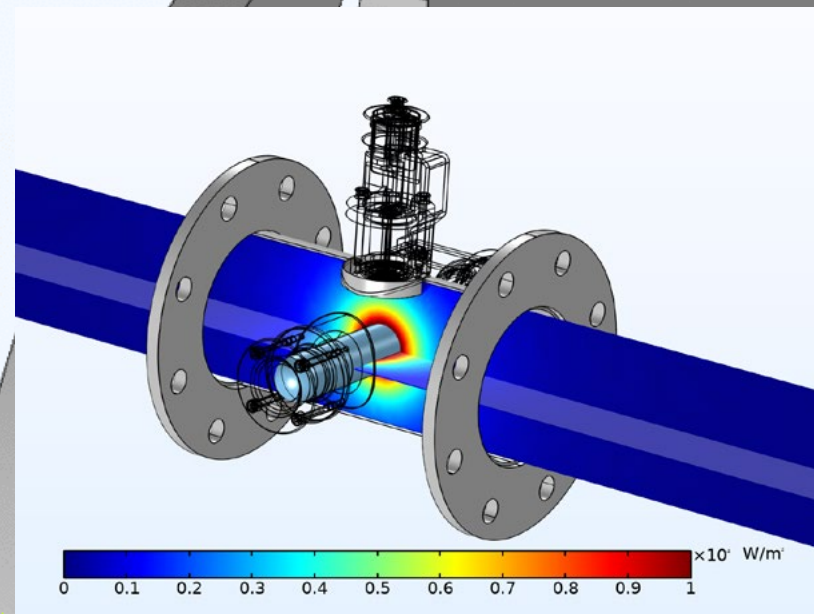
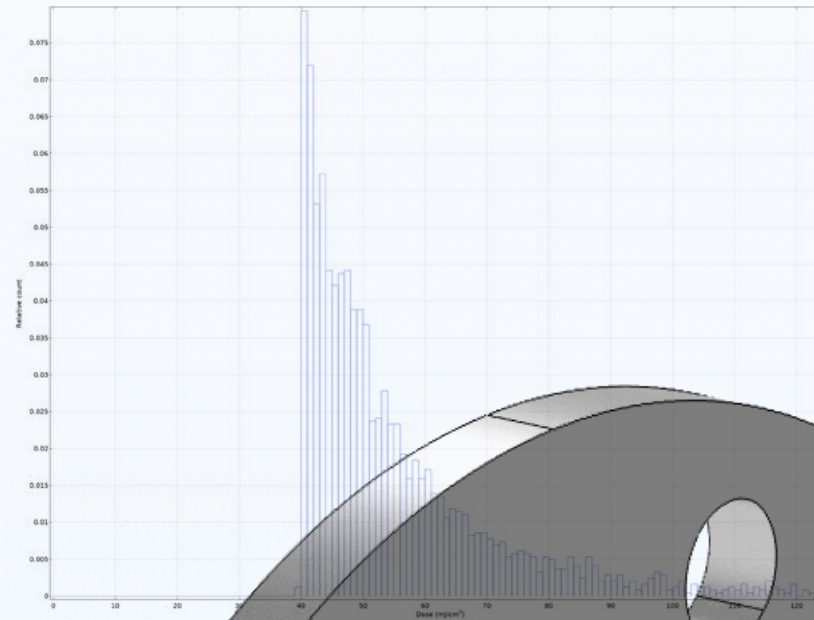

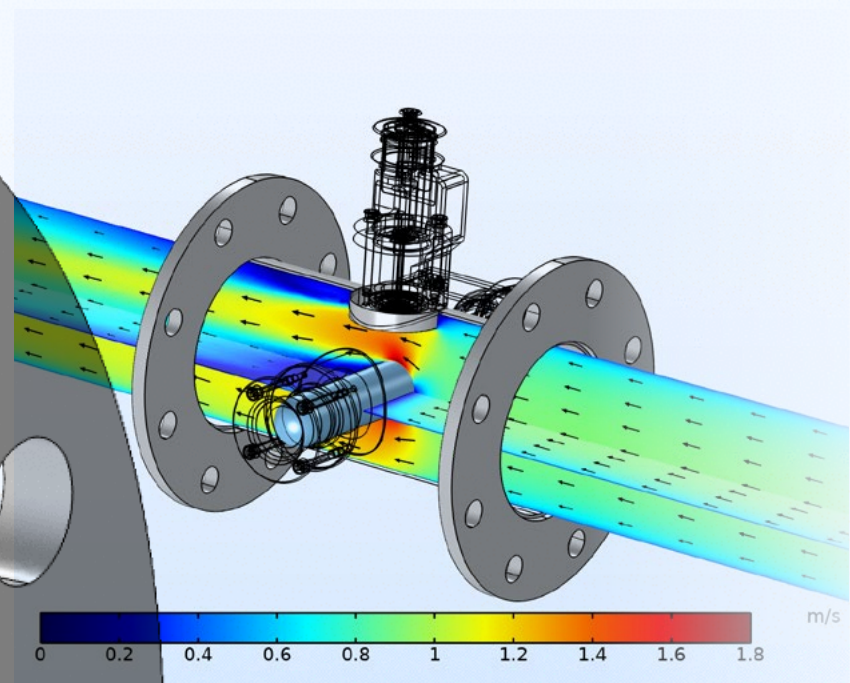
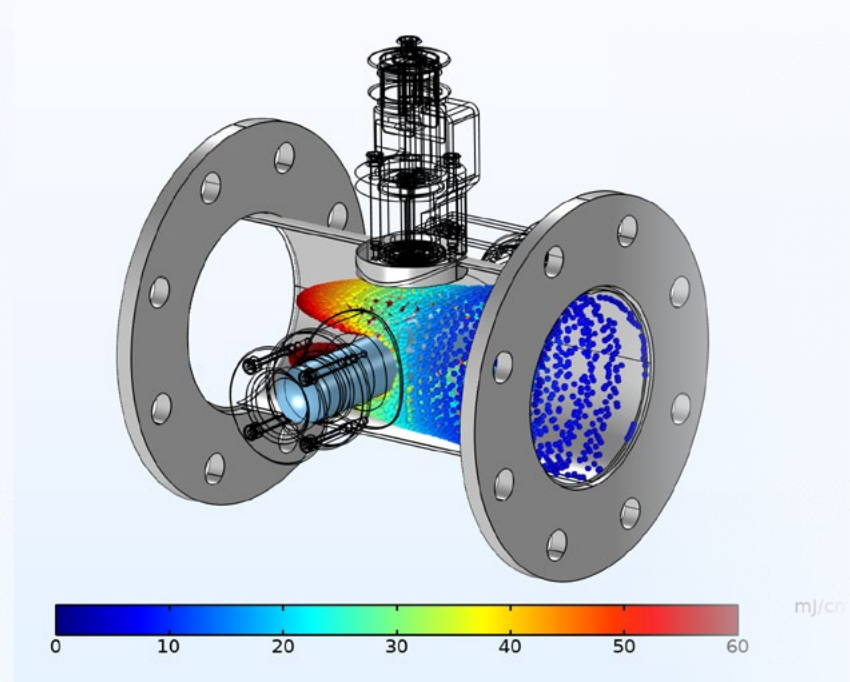
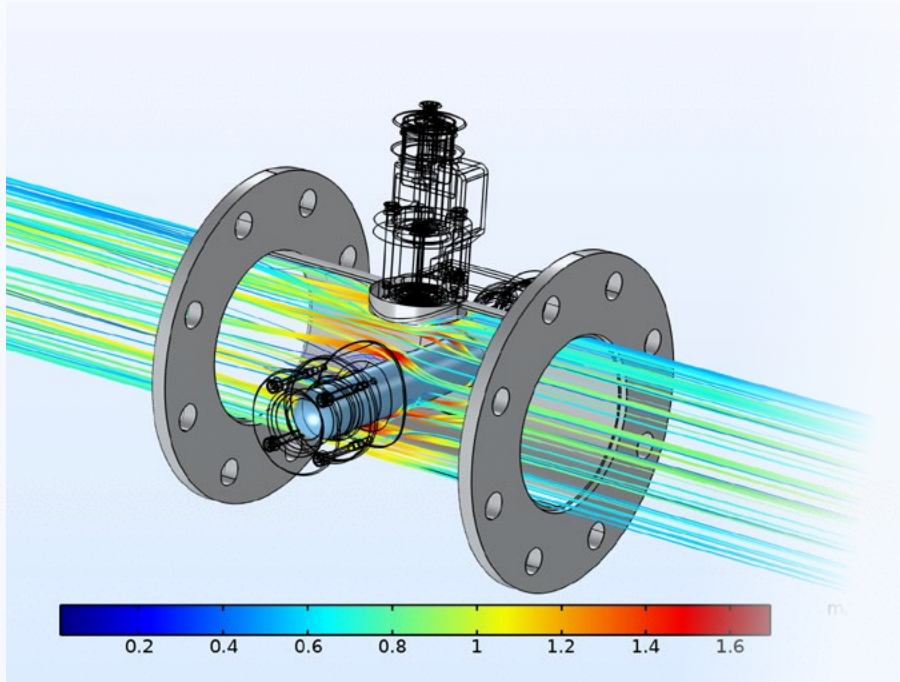
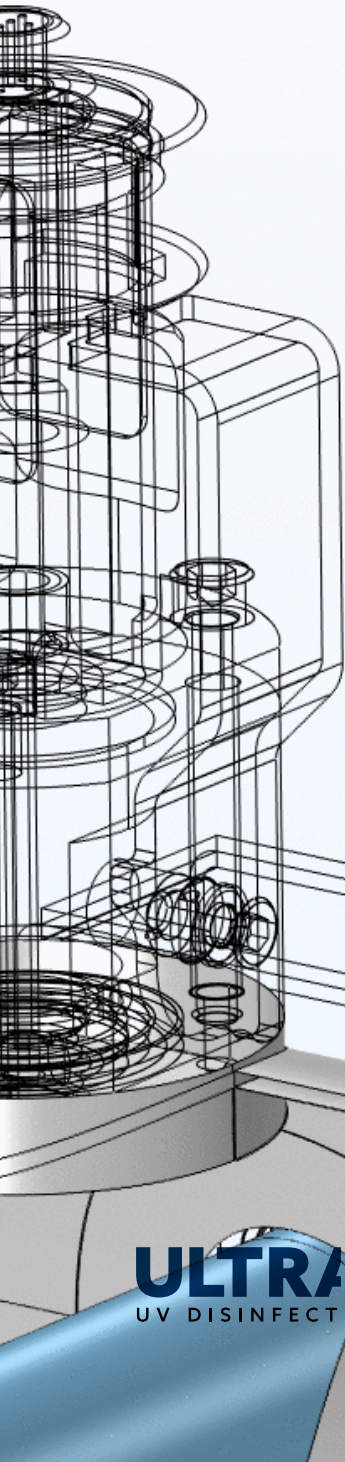

ULTRAQUA
UV DISINFECTION SYSTEMS

R&D CAPACITIES

SINCE 1996, THE R&D DEPARTMENT HAS BEEN THE BACKBONE OF ULTRAAQUA.

Employing the brightest industry specialists with great diversity for continuous innovation has been vital to the success of the company.

The ULTRAAQUA R&D department conducts, supports, and pioneers some of the latest developmental work within the water industry. These projects are often done in collaboration with specialists from municipalities, universities, top tier consultancies and international companies. The projects are primarily focused on developing unique and advanced chemical free disinfection solution for some of the worlds most complex water quality problems.

Members of the Ultraaqua team staff include many engineers within chemistry, water treatment, mechanics, computational fluid dynamics and process control. Several scientists and Ph.Ds. Ultraaqua scientific staff are involved in many EU and national funded science projects generating leading edge knowledge. In house Computational Fluid Dynamics (CFD) staff has modelled the MULTIRAY range and optimized design for disinfection and combined chlorine reduction.

The comprehensive in-house testing area facilitates optimal conditions for research, development, and innovation. With the ability to run full scale pilot trials and a 40 ft research container to support local testing combined with cutting edge engineering, makes us confident that ULTRAAQUA is the right partner for your organization.

This ultimately allows ULTRAAQUA to position itself amongst the industry leaders within UV disinfection, supplying customers with the best available solutions.



ULTRAAQUA

SERVICE & SUPPORT

ULTRAAQUA IS A GLOBAL COMPANY OFFERING WORLDWIDE SERVICE AND SUPPORT, WITH ITS HEAD OFFICE BASED IN DENMARK.

With over 10.000 systems installed in over 120 countries, ULTRAAQUA offers extensive support regarding installation and maintenance through a wide-ranging network of regional offices.

The technical support team at our head office provides 24-hour remote service upon agreement to reduce the risk of emergencies.

At ULTRAAQUA, it is our goal to provide a complete product experience for our customers, from specifying requirements to ongoing operational maintenance. This naturally means that our responsibility does not stop after the UV system reaches its destination.

By maintaining close collaboration with all clients, a trouble-free process is ensured throughout all post-installation activities.

The support services include, but are not limited to:

- General technical support
- Advanced 24-hour support upon agreement
- Spare part ordering and shipping services
- Commissioning
- On-site training
- On-site technical support

If necessary, qualified engineers are available for on-site training and technical support, able to assist in setting up the complete solution. To ensure maximum system performance and reliability, extensive information and technical knowledge are always provided.



COMPANY HISTORY

ULTRAAQUA IS AN INTERNATIONAL MANUFACTURER OF ADVANCED UV WATER DISINFECTION SYSTEMS FOR A WIDE RANGE OF WATER TREATMENT APPLICATIONS.

The company was founded in 1996 by two Danish scientists, with the mission of solving the increasing global water safety challenges, by combining extensive research, innovation, and technology. Today, more than 10.000 UV disinfection systems have been supplied worldwide, to help create a more sustainable world.

ULTRAAQUA operates through a carefully selected partner network, with activity in more than 120 countries. The partner network has been key to the success of ULTRAAQUA, making it possible to deliver cutting-edge UV disinfection systems across the globe.

Continuous research and innovation activities have made it possible to maintain the position of delivering cutting-edge solutions to clients with diverse requirements in different applications.

Global experience combined with advanced knowledge of dealing with varying customer requirements, ensures an optimal solution to accommodate every client. Combined with a dedicated support experience, a streamlined operational process is guaranteed.

WANT TO LEARN MORE?



 www.ultraaqua.com

 (+45) 70 23 10 20

 sales@ultraaqua.com

ULTRAAQUA
UV DISINFECTION SYSTEMS